



English

norcool
cold by nature



OPERATING & INSTALLATION INSTRUCTIONS



CU-350 ECO | CU-450 ECO | CU-900 ECO



Please visit www.norcool.no for operating & installation instructions in other languages.

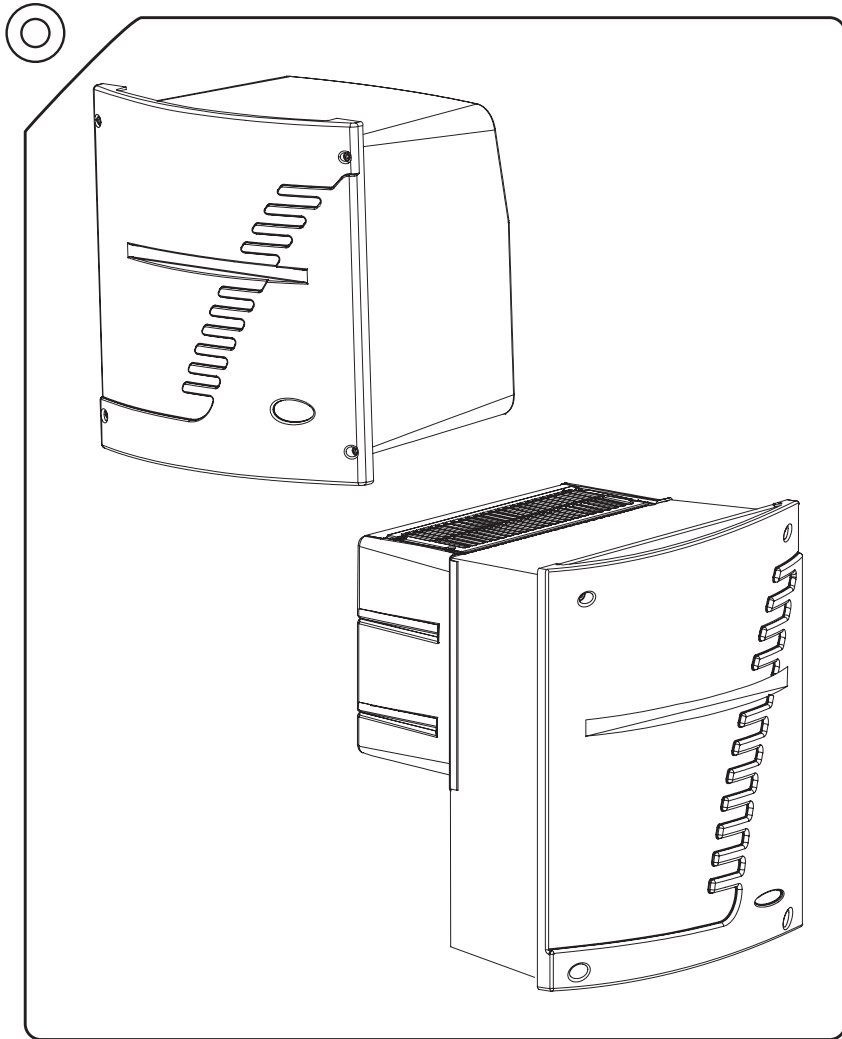

1.	Product information	9
2.	Important information	11
3.	Dimensions and technical specifications	12
4.	Pre-installation	13
5.	Installation instructions	14
6.	Using the appliance	15
6.1	Controller icons and temperature settings	16
6.2	Switching on/off the light	16
6.3	Manual defrost	16
6.4	Alarm function	16
6.5	Cleaning and maintenance	17
7.	Service and troubleshooting	18
8.	Disposal of used products	19
9.	CU-350 ECO Item list	20
10.	CU-450 ECO Item list	21
11.	CU-900 ECO Item list	22

This appliance is not intended for use by persons (including children) with reduced physical, sensory or mental capabilities, or lack of experience and knowledge, unless they have been given supervision or instruction concerning use of the appliance by a person responsible for their safety. Children should be supervised to ensure that they do not play with the appliance.

This appliance can be used by children aged from 8 years and above and persons with reduced physical, sensory or mental capabilities or lack of experience and knowledge if they have been given supervision or instruction concerning use of the appliance. Cleaning and user maintenance shall not be made by children without supervision.

To avoid contamination of food, please respect the following instructions:

- Opening the door for long periods can cause a significant increase of the temperature in the compartments of the appliance.
- Clean regularly surfaces that can come in contact with food and accessible drainage systems.
- Store raw meat and fish in suitable containers in the refrigerator, so that it is not in contact with or drip onto other food.
- If it is left empty for long periods, switch off, defrost, clean, dry, and leave the door open to prevent mould developing within the cooling room.

Appliances shall be constructed so that lubricants are prevented from polluting food compartments.

WARNING: Use this appliance only for its intended purpose as described in this instruction manual. The appliance must be properly installed in accordance with the manual before it is used.

WARNING: When positioning the appliance, ensure the mains power cable is not trapped or damaged.

WARNING: Do not connect unit to multiple portable socket-outlets or portable power supplies.



Caution: risk of fire/flammable materials Refrigerant R290, this gas is natural gas with high environmental compatibility that is, however, also combustible.

When transporting and installing the appliance, ensure that no parts of refrigerating circuit are damaged.

Refrigerant leaked from the refrigerating pipes could ignite, if leaking is detected, to avoid any potential source of ignition (spark, naked flames etc.), please open window or door, and keep good ventilating.

For appliances which use flammable refrigerants, the instructions shall include information pertaining to the handling, servicing and disposal of the appliance. The appliance has to be unplugged after use and before carrying out user maintenance on the appliance. If the supply cord is damaged, it must be replaced by the manufacturer, its service agent or similarly qualified persons in order to avoid a hazard.

WARNING: Connect the supplied plastic tube to the water overflow pipe on the cold side of the unit, and connect this to a permanent drainage or water container.

WARNING: Keep ventilation openings, in the appliance enclosure or in the built-in structure, clear of obstruction.

WARNING: Do not use electrical appliances inside the cold room unless they are of the type recommended by the manufacturer.

WARNING: Do not damage the refrigerant circuit.

WARNING: Do not store explosive substances such as aerosol cans with a flammable propellant in the cold room of this appliance.

WARNING: The door to use for assembling the cold room, shall be made in a way that can be opened from the inside with a force smaller than 70N.

This appliance is intended to be used in households and similar applications such as:

- staff kitchen areas in shops, offices and other working environments;
- farm houses and by clients in hotels, motels and other residential type environments;
- bed and breakfast type environments;
- catering and similar non-retail applications.

The instructions for built-in appliances shall include information with regard to the following:

- dimensions of the space to be provided for the appliance;
- dimensions and position of the means for supporting and fixing the appliance within this space;
- minimum distances between the various parts of the appliance within this space;
- minimum dimensions of ventilating openings and their correct arrangement;
- connection of the appliance from the supply mains and the interconnection of any separate components;
- necessity to allow disconnection of the appliance from the supply after installation, unless the appliance incorporates a switch complying with 24.3. The disconnection may be achieved by having the plug accessible or by incorporating a switch in the fixed wiring in accordance with the wiring rules.

If the supply cord is damaged, it must be replaced by the manufacturer, its service agent or similarly qualified persons in order to avoid a hazard.

The product is intended for use within definite climate classes (ambient temperature) and ought not to be used outside such limits. The climate classes are specified on the type plate on the inside of the product.

With respect to the climate specifications, this product must be used in climate class ST, which means an ambient temperature of +16 °C to +38 °C.

Climate class	Ambient/room temperature
SN	+ 10 °C to + 32 °C
N	+ 16 °C to + 32 °C
ST	+ 16 °C to + 38 °C
T	+ 16 °C to + 43 °C
SN - ST	+ 10 °C to + 38 °C
SN - T	+ 10 °C to + 43 °C

1. Product information

These compact units come in three models; CU-350 ECO, CU-450 ECO and CU-900 ECO with varying capacity depending on the size of the cold room. They are for installation in a recess in the wall of a cold room. Do not use foam insulation when mounting the unit in the recess niche. The units have a 'cold side' - the element which projects into the cold room and a 'warm side' - the element which projects into the outside of the cold room.

They are designed for chilling food for use in private households and similar applications. The unit cannot be placed on the outside wall or against an uninsulated garage. The correct temperature in the cold room will depend on correct construction and insulation. Leave the refrigeration unit inactive after installation for approx. 2 hours before connecting to the mains electricity. This will allow the oil to run back into the compressor after transportation and installation. If it has been stored in sub- zero temperatures, allow to stand for 24 hours at room temperature before starting.

There must be an adequate distance to the ceiling over the unit on the warm side to allow disposal of the hot air produced. The units require a power supply of 220-240VAC 50 Hz and must be connected to an earthed min.10A mains socket. If the power cable is not long enough (2.6m mains cable connected to warm side), call an electrician to install an extra min.10A earthed socket. If the unit does not start as soon as it is plugged in, it will start after a delay of up to 7 minutes. In the event of full load or frequent door opening/closing, the compressor will run longer and it will take longer to reach the desired room temperature. Keep the door closed as much as possible. Ambient temperature on the warm side of the unit must always be higher than set temperature inside the cold room, but must not exceed 38°C, or be less than 16°C.

Ambient temperature

An explanation shall be given of the meaning of the alpha-numeric characters, indicating the test room climatic class of the appliance, that are marked on the appliance.

Test room climate class	Dry bulb temperature °C	Relative humidity %	Dew point °C	Water weight in dry air g/kg
0	20	50	9.3	7.3
1	16	80	12.6	9.1
2	22	65	15.2	10.8
3	25	60	16.7	12
4	30	55	20	14.8
5	40	40	23.9	18.8
6	27	70	21	15.8
7	35	75	30	27.3

This product is defined as a customized product and is an unconventional refrigeration appliance. Only one single batch is produced. The main function of this product is not to store food through a refrigeration system, but to provide a refrigeration environment.

Scandinavian Appliances AS also supplies other products that you need for a self-built cold room. We can offer two different cold room doors; the D-2000 with a fixed frame, a door that is designed for integration by using a furniture front. The D-1900, which is an externally-mounted white door, this door is not designed for integration. We also stock fixture packs of wire shelves of various lengths, baskets and wine racks, plus shelf rails and rests.

Scandinavian Appliances AS consumer products are sold for normal use in private households. To ensure correct installation and use and thus maximise product lifetime, please read these instructions carefully before starting installation. The manufacturer cannot be held liable for damage caused through failure to follow the instructions in this guide. The product will require maintenance even in normal use. Scandinavian Appliances AS follow the guarantee in accordance with the Sale of Goods Act.

Electrical safety for the appliance is only guaranteed if the earthing system in the house has been installed correctly and that the voltage is as specified in this guide. Never allow the unit to be connected to an extension cord permanently. The mains socket must be easily accessible for installation/ service. Disconnect plug when cleaning. Other authorities can apply regulations for e.g. lighting, alarm and the like with regard to installation. Repairs must only be made by qualified personnel.

Data plate with serial number is located behind the front cover on the warm side. Serial number must always be stated when contacting service engineer or manufacturer. Scandinavian Appliances AS cannot be held liable for any printing errors in these user instructions and reserves the right to change product specifications.

External lamp power supply

**AC 220-240V SOCKET
FOR EXTERNAL LIGHT ONLY
MAX POWER 20W**
KEEP PROTECTIVE CAP CLOSED WHEN NOT IN USE

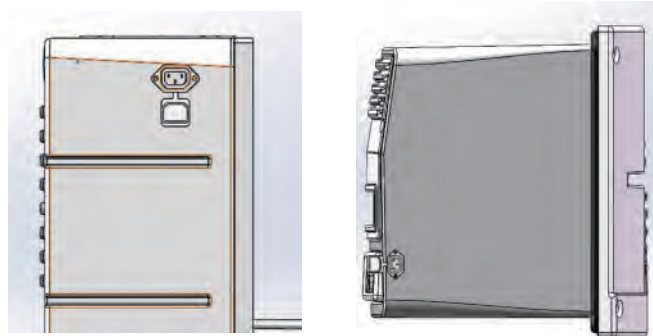
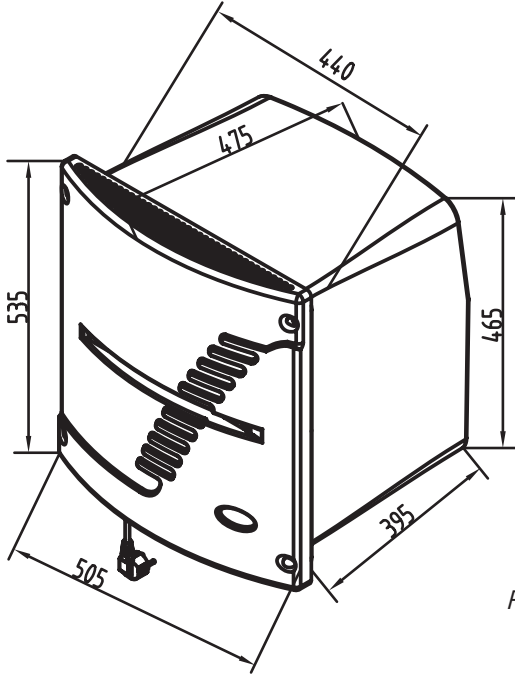

Figure 1

3. Dimensions and Technical Specification

Dimensions: CU-350 ECO



Dimensions: CU-450 ECO and CU-900 ECO

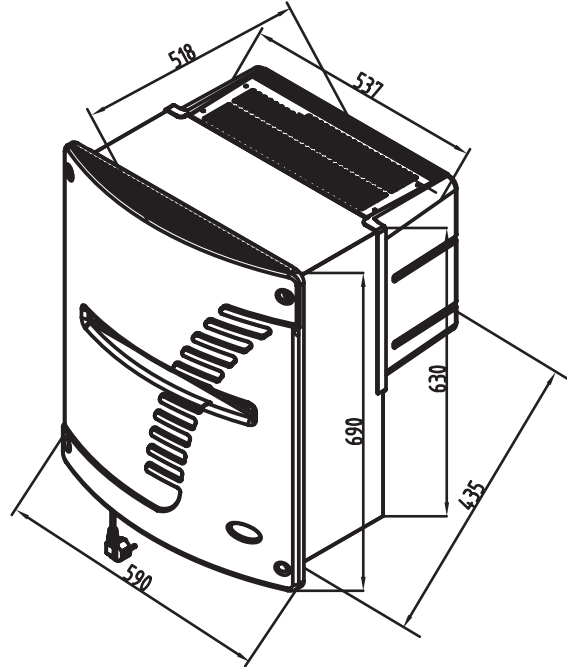

Figure 2

Description	CU-350 ECO	CU-450 ECO	CU-900 ECO
External dimensions	w505 x d475 x h535 mm	w590 x d518 x h690 mm	w590 x d518 x h690 mm
Wall recess	w460 x h490 mm	w550 x h650 mm	w550 x h650 mm
Power Max.	Max. 400W	Max. 500W	Max. 800W
Lighting	5W LED	6.5W LED	6.5W LED
External Lightning Socket	MAX 20W LED	MAX 20W LED	MAX 20W LED
Defrost	Automatic	Automatic	Automatic
Water overflow system	Connect hose to drainage tube	Connect hose to drainage tube	Connect hose to drainage tube
Insulation	Polyurethane foam, non-CFC	Polyurethane foam, non-CFC	Polyurethane foam, non-CFC
Coolant	R290	R290	R290
Net weight	28 kg	33 kg	37,5 kg
Power cable length	2.6m	2.6m	2.6m
Volt/Hz	220-240V AC 50Hz	220-240V AC 50Hz	220-240V AC 50Hz
Capacity	Up to 5000 litres	Up to 10,000 litres	Up to 20,000 litres
Thermostat setting	2-18 °C (default 5 °C)	2-18 °C (default 5 °C)	2-18 °C (default 5 °C)
Ambient temperature	16-38 °C	16-38 °C	16-38 °C
Maximum wall thickness	330mm	230mm	230mm
Min. distance to ceiling cold side	100mm	200mm	200mm
Min. distance to ceiling/floor warm side	500mm/500mm	500mm/500mm	500mm/500mm

First, unpack the cooling unit and check for any transportation damage. Do not use a damaged cooling unit. In the event of damage, please contact the shipping company and make sure that the damage is noted on the consignment note. Check that all the items on the item list are present. Contact the manufacturer in the event of damage or missing parts.

Check that the wall recess has the correct dimensions for your unit and that the distance to the ceiling is correct (see dimensions and technical specifications). Also ensure that the unit is placed as high as possible on the wall for stable temperature in the cold room. Distance between walls in the cold room must be min. 1000 mm to prevent the cold air from stagnating around the unit. Do not place the unit directly opposite the door as this can cause condensation on the magnetic seals. Do not place the unit over a heat source.

If the power cable is not long enough, have an electrician to install a minimum 10A-earthed socket closer to the unit. Never allow the unit to be permanently connected via an extension cord.

1. Attach the wide foam tape to the lower surface of the wall recess with the adhesive side down.
2. Slide into the wall recess from the outside of the cold room until it stops against the edge. Centre unit in the wall recess and screw securely to the wall using the 4 screws supplied. Tighten these screws until the rubber seal is pressed gently against the wall.
3. Mount front cover using the 4 screws supplied.
4. Insert insulation between unit and wall recess from the cold room side. Ensure that all sides of the unit are insulated! **NOTE:** Do not pack insulation tightly or use foam insulation around the cooling unit.
5. Fasten D-seal to the wall around unit on the cold side before mounting interior trims (trims are optional, and not supplied with the product). This is important to avoid vibration transferring to the wall structure.
6. Connect the supplied drainage hose to the overflow plastic drainage tube located at the bottom of the unit inside the cold room, and then place the other free end to an external water container or the house drainage installation.

CU-350 ECO

1. 4 pcs. screws for front cover
2. Front cover
3. Screws for securing unit to wall
4. Rubber seal for flange
5. Wide foam tape
6. Wooden seals
7. Insulation
8. D-seal
9. Drain

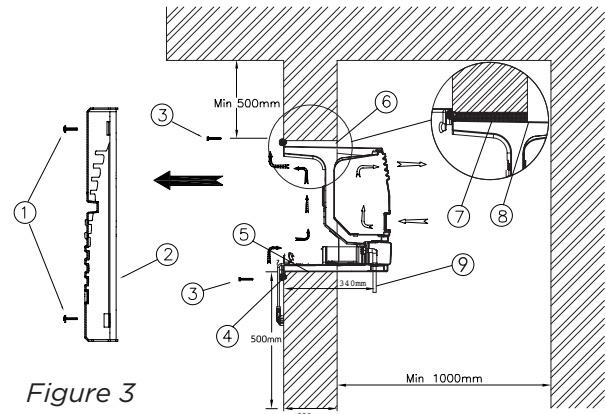

Figure 3

CU-450 ECO, CU-900 ECO

1. 4 pcs. screws for front cover
2. Front cover
3. Screws for securing unit to wall
4. Rubber seal for flange
5. Wide foam tape
6. Wooden seals
7. Insulation
8. D-seal
9. Drain

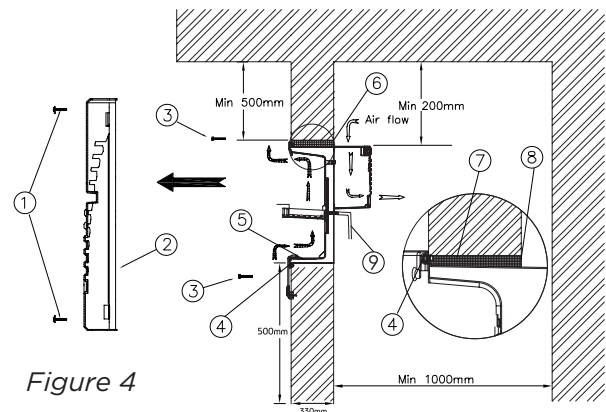



Figure 4





Using the appliance

	<ul style="list-style-type: none"> • Keep clear of obstruction all ventilation openings in the appliance enclosure or in the structure for building-in. • Do not use mechanical devices or other means to accelerate the defrosting process, other than those recommended by the manufacturer. • Do not damage the refrigerant circuit. • Do not store explosive substances such as aerosol cans with a flammable propellant in the cold room of this appliance. • Do not use electrical appliances inside the cold room of the appliance, unless they are of the type recommended by the manufacturer. • The door to use for assembling the cold room, shall be made in a way that can be opened from the inside with a force smaller than 70N.
---	--

	<p>Concerning the cooling room this cooling unit is built into, observe the following:</p> <ul style="list-style-type: none"> • Children aged from 3 to 8 years are allowed to load and unload the cooling room. • Consider the temperature distribution in the cooling room concerning storage of specific types of food. • Opening the door for long periods can cause a significant increase of the temperature in the compartment of the appliance. • Clear regularly surfaces that can come in contact with food and accessible drainage systems. • Store raw meat and fish in suitable containers in the refrigerator, so that it is not in contact with or drip onto other food. • If it is left empty for long periods, switch off, defrost, clean, dry, and leave the door open to prevent mould developing within the cooling room.
---	---

6.1 Controller icons and temperature settings

The unit is equipped with an electronic controller located on the cover of the cold side.

-  Indicates compressor is activated.
-  Indicates fan is activated.
-  Indicates defrosting is activated.
-  Indicates parameter programming.
-  Indicates buzzer alarm occurred.



The controller has a range of 2 °C – 18 °C, with default setting of 5 °C. In order to adjust the set point please follow the below steps:

- Press and hold 'SET' for two seconds, the display will flash the current set point value.
- Press 'UP' or 'DOWN' arrow button to adjust the temperature.
- Press 'SET' again or do nothing for 30 seconds and the system will automatically save the setting and end setting mode

6.2 Switching on / off the light

- Press 'Lig' to turn on/off the light.

6.3 Manual defrost

- Press and hold 'def/down' button for 8 seconds to start manual defrost. The defrost will stop automatically when the deicing temperature is reached.

6.4 Alarm function

If the temperature of the compressor exceeds a specific value the controller will generate an audible alarm. If the alarm sounds and the display show the code "ACH" you need to clean the condenser filter and the condenser as described in the "Cleaning & Maintenance" section and reset the alarm by pressing the "Mute" controller button. If the problem persists, please order service call.

If the compressor's temperature exceeds the compressor's operating temperature limits, the controller will generate an audible alarm and shut down the cooling system, as high temperatures can reduce the cooler's service life considerably. In this case you need to clean both the filter and the condenser as described in the "Cleaning & Maintenance" section, and reset the alarm and the cooling system by pressing the "Mute" controller button. If the problem persists, please order service call.

6.5 Cleaning and maintenance

It is important to clean the condenser dust filter at least four times a year, and the condenser at least once a year, to ensure performance. The consumer is responsible for keeping the filter and the condenser clean. This is essential to ensure that the guarantee will apply in the event of unit malfunction.

Filter Cleaning

- Unplug the unit from the mains.
- Remove the filter by pulling it out from the slot located in the plastic cover of the warm side.
- Vacuum or wash it thoroughly with warm water to completely remove accumulated dust.
- Dry and reinstall the filter by inserting it to the front cover slot.

Condenser Cleaning

- Unplug the unit from the mains.
- Remove the condenser filter as instructed above.
- Unscrew the 4 screws on the front cover and remove it (fig 5).
- Vacuum clean or gently brush the visible condenser fins under the large steel bracket. Be careful not to damage the thin fins. This will reduce the unit's cooling function.
- Fix the front cover with the 4 screws and insert the condenser filter.

In very dusty conditions, clean the condenser at least twice a year and check that the unit is properly clean. This can be done by projecting a light from the underside up through the condenser fins using a flashlight. When looking directly down on the fans, it should be possible to see the light through the fins. If the light cannot penetrate, there is still too much dust in the unit.

To avoid mould forming, bad smells etc. regular cleaning of the unit is essential. We recommend mild, warm soapy water for cleaning the unit and the water collector located inside the cold room.

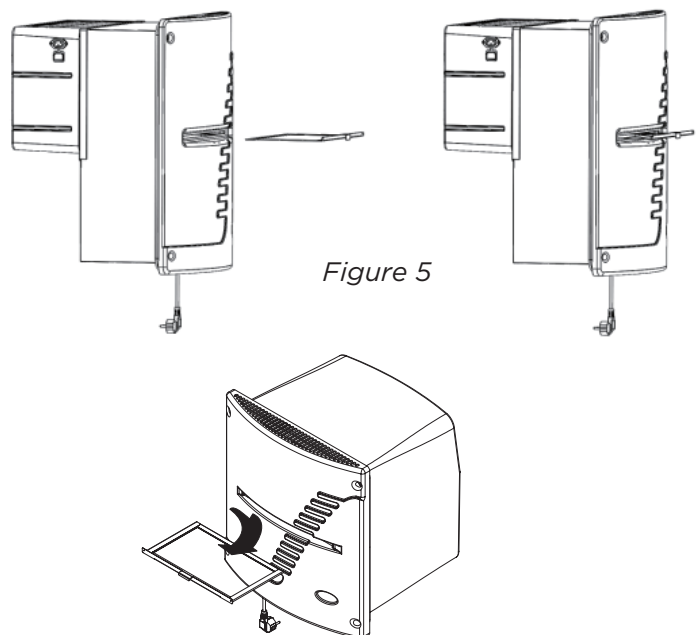

7. Services and Troubleshooting

FAULT	CAUSE	REMEDY
Unit not cooling sufficiently.	<ol style="list-style-type: none"> 1. Controller set point too high. 2. Ambient temperature too high. 3. Ambient temperature too low. 4. Door not sealed/closed. 5. Condenser blocked (dust etc.). 6. Evaporator iced up. 	<ol style="list-style-type: none"> 1. Adjust set point to lower value. 2. Reduce temperature in room at the unit's warm side. Check that the air flow is unobstructed over and under the unit. 3. Increase temperature in room at the unit's warm side. 4. Check door is sealed/closed. 5. Remove and clean dust filter. 6. Switch off the unit to defrost.
Unit not working	<ol style="list-style-type: none"> 1. Fuses. 2. Mains power cable. 	<ol style="list-style-type: none"> 1. Check fuses in main house fuse box. 2. Check power cable is properly-connected to the mains socket.
Light/fan not working.	<ol style="list-style-type: none"> 1. LED or power supply defective. 2. Fan defective. 	<ol style="list-style-type: none"> 1. Order service call. 2. Order service call.
Water leak	<ol style="list-style-type: none"> 1. Drainpipe blocked. 2. Drip pan leaking. 3. Warm air getting into cold room. 	<ol style="list-style-type: none"> 1. If possible, remove blockage. 2. Order service call. 3. Check magnetic seal on door, locate leak and repair.
Controller Error code	<ol style="list-style-type: none"> 1. E0, temperature sensor error. 2. E1, defrost sensor error. 3. E2, condenser sensor error. 4. H1, high temperature alarm. 5. AC, condenser high temperature alarm. 6. ACH, condenser excess temperature alarm. 	<ol style="list-style-type: none"> 1.- 3. Unplug the power cord for two minutes, and reconnect. If problem remains, order service call. 4. Check compressor icon, order service call. 5. Clean the dust filter, and check that airflow is unobstructed over and under the front cover on warm side. 6. Clean dust filter.

For service, see our website at www.norcool.com.

By checking the above before calling for service help, you will help the service engineer know what parts they may need to bring and what measures to take.

Waste management of the packaging:

The packaging protects the product against damage during transport. All packaging may be recycled and is labelled for recycling. Make sure that all packaging is discarded in a safe manner and is stored out of reach of children since irresponsible use may be dangerous. Ask the dealer or local authorities about where the packaging may be delivered for recycling.



Waste management of the product:

This product falls under EU Directive 2012/19/EU concerning waste from electrical and electronic equipment (WEEE). This symbol specifies that the product must not be treated as household waste. Valuable raw materials may be recovered by recycling used products. By ensuring that the product is recycled correctly, you can contribute to preventing potential negative consequences to the environment and human health.

When the product is to be discarded:

1. Pull out the mains plug.
2. Cut off the power cable.
3. Check that the cooling circuit is not damaged prior to waste management. Information in the coolant is specified on the type plate.
4. Products that are no longer in use must be handled in a professional and correct manner in accordance with local statutes and regulations.

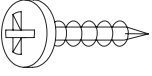
Figure:	Description:	Item number:	Qty:
	CU-350 ECO	12600000	1
	Front cover	8900006772	1
	D-shape gasket 6x9 .6x2000mm	8900006774	1
	Wide foam tape	8900006769	2
	ST4x30	8900006767	4
	M5x16	8900006768	4
	User manual	8900006770	1
	Drain tube Ø11x1500mm	8900006771	1
	Pipe clamp	8900006766	1

10. CU-450 ECO Item List

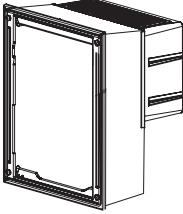
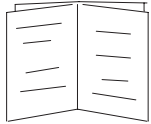

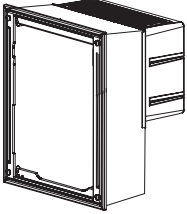
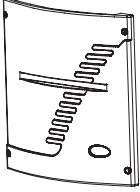
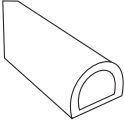
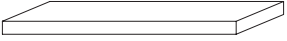
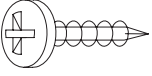
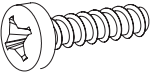



Figure:	Description:	Item number:	Qty:
	CU-450 ECO	12600050	1
	Front cover	8900006773	1
	D-shape gasket 6x9 .6x2500mm	8900006775	1
	Wide foam tape	8900006769	2
	ST4x30	8900006767	4
	M5x16	8900006768	4
	User manual	8900006770	1
	Drain tube Ø11x1500mm	8900006771	1
	Pipe clamp	8900006766	1

Figure:	Description:	Item number:	Qty:
	CU-900 ECO	12600150	1
	Front cover	8900006773	1
	D-shape gasket 6x9.6x2500mm	8900006775	1
	Wide foam tape	8900006769	2
	ST4x30	8900006767	4
	M5x16	8900006768	4
	User manual	8900006770	1
	Drain tube Ø11x1500mm	8900006771	1
	Pipe clamp	8900006766	1



Scandinavian Appliances AS
Postboks 61
1740 Borgenhaugen
Norway
T: +47 815 69 117
post@norcool.no
www.norcool.no



Please visit our website for operating & installation instructions in other languages.

Version 1.1 - feb 2023