

## PRODUCT ADVANTAGES

- Practical solution for wheelchair users and easy accessibility for children
- Integrates with all types of kitchens
- Maintenance-free with automatic defrosting
- Digital thermostat
- LED light
- Door alarm
- Adjustable legs for easier installation

Model	Item number
Drawer Freezer for kitchen integration	60000008

Accessories	Item number
Front panel, black matte	8900013831
Front panel, steel	8900013832

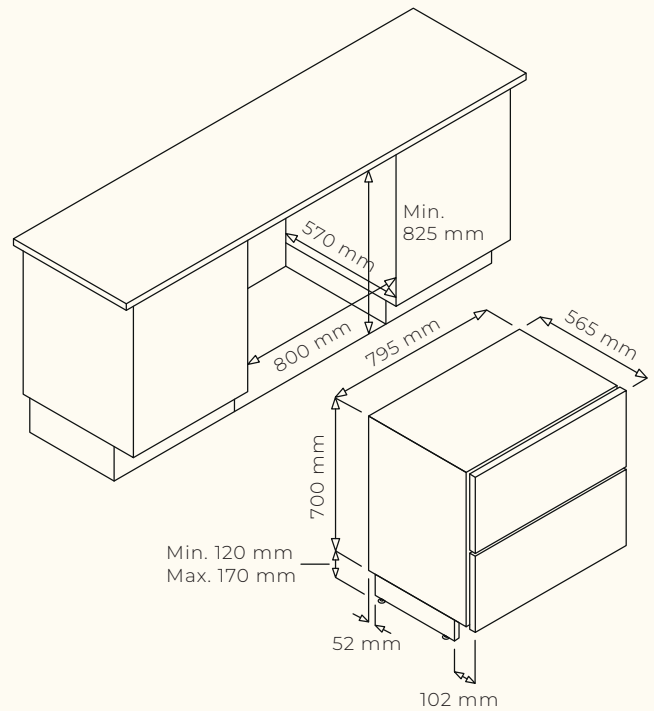
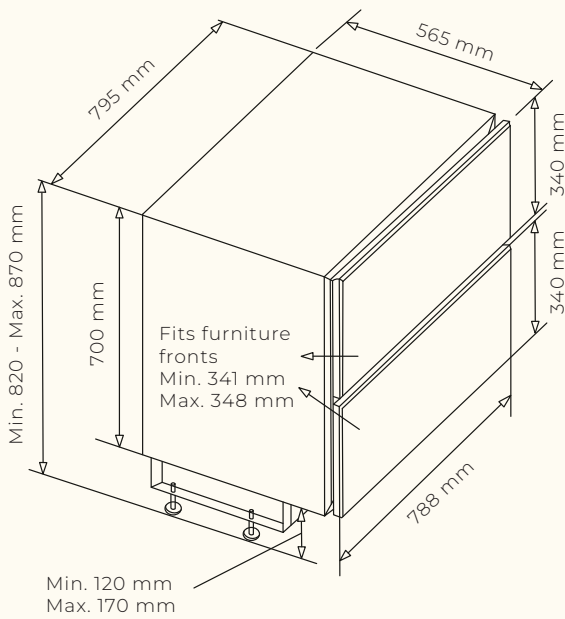

## TECHNICAL DATA

### Dimensions

External dimensions	W795 x H820-870 x D565 mm
Niche dimensions	W800 x H825 (min.) x D565 mm
Volume	104 liters
Weight	70 kg
For integration	Yes
Power cable	2,4 meters

### Noise

Noise level	38 dB
-------------	-------

### Temperature

Temperature range	-18/-24 °C
Ambient temperature	16-32 °C
Defrosting	Automatic

### Energy

Consumption	329 kWh/year
Energy class	D
Lighting	LED light
Coolant	R600A

### Drawers

Number of drawers	2 large drawers
Alarm	Yes, turns on after 30 seconds

### Ventilation

Requires ventilation	Ventilation grille in the floor plinth – included. Aluminum grille is delivered as a standard
----------------------	---