



English

norcool



# OPERATING & INSTALLATION INSTRUCTIONS

---

FREEZER DRAWER

---





Please visit **[en.norcool.com](http://en.norcool.com)** for operating & installation instructions in other languages.

# Content

<b>1.</b> Handling of waste .....	<b>5</b>
<b>2.</b> Safety rules and warnings .....	<b>6</b>
<b>3.</b> Product information .....	<b>8</b>
<b>4.</b> Environment and energy conservation .....	<b>9</b>
<b>5.</b> Important information .....	<b>10</b>
<b>6.</b> Dimensions and technical specifications.....	<b>11</b>
<b>7.</b> Back legs adjustments .....	<b>12</b>
<b>8.</b> Pre-installation .....	<b>13</b>
<b>9.</b> Installation .....	<b>14</b>
<b>10.</b> Fitting/removing drawers .....	<b>16</b>
<b>10.1</b> Removing front/drawer .....	<b>16</b>
<b>10.2</b> Side adjustment .....	<b>16</b>
<b>10.3</b> Tilt adjustment .....	<b>16</b>
<b>11.</b> Use and maintenance .....	<b>17</b>
<b>11.1</b> Prior to start .....	<b>17</b>
<b>11.2</b> Maintenance .....	<b>17</b>
<b>11.3</b> Manual defrosting .....	<b>17</b>
<b>11.4</b> Noises .....	<b>17</b>
<b>11.5</b> Display panel .....	<b>18</b>
<b>11.6</b> Troubleshooting and service .....	<b>19</b>
<b>12.</b> Delivery terms and conditions .....	<b>20</b>
<b>12.1</b> Consumer purchases .....	<b>20</b>
<b>12.2</b> Business purchases.....	<b>21</b>
<b>13.</b> Package list .....	<b>22</b>

# 1. Handling of waste

## Waste management of the packaging:

The packaging protects the product against damage during transport. All packaging may be recycled and is labelled for recycling. Make sure that all packaging is discarded in a safe manner and is stored out of reach of children since irresponsible use may be dangerous. Ask the dealer or local authorities about where the packaging may be delivered for recycling.

## Waste management of the product:

This product falls under EU Directive 2012/19/EU concerning waste from electrical and electronic equipment (WEEE). This symbol specifies that the product must not be treated as household waste. Valuable raw materials may be recovered by recycling used products. By ensuring that the product is recycled correctly, you can contribute to preventing potential negative consequences to the environment and human health.



## When the product is to be discarded:

1. Pull out the mains plug.
2. Cut off the power cable.
3. Check that the cooling circuit is not damaged prior to waste management. Information in the coolant is specified on the type plate.
4. Products that are no longer in use must be handled in a professional and correct manner in accordance with local statutes and regulations.

## Warning:

- The appliance is not to be used by persons (including children) with reduced physical, sensory or mental capabilities, or lack of experience and knowledge, unless they have been given supervision or instruction.
- Children being supervised not to play with the appliance.
- Keep ventilation openings, in the appliance enclosure or in the built-in structure, clear of obstruction.
- Do not use mechanical devices or other means to accelerate the defrosting process, other than those recommended by the manufacturer.
- Do not damage the refrigerant circuit.
- This warning is only applicable for appliances with refrigerating circuits which are accessible by the user.
- Do not use electrical appliances inside the food storage compartments of the appliance, unless they are of the type recommended by the manufacturer.
- Do not store explosive substances such as aerosol cans with a flammable propellant in this appliance.
- When positioning the appliance, ensure the supply cord is not trapped or damaged.
- Do not locate multiple portable socket-outlets or portable power supplies at the rear of the appliance.

## 2. Safety rules and warnings

THE MANUFACTURER OF THE PRODUCT CANNOT BE HELD RESPONSIBLE FOR DAMAGE THAT IS DUE TO THESE SAFETY RULES AND WARNINGS NOT BEING FOLLOWED.

1. Read the use and installation instructions carefully before you start using the product.
2. This product is intended for private use. The manufacturer cannot be held responsible for damage in consequence of erroneous or unintended use of the product.
3. Persons, who due to their mental or physical conditions, or due to their inexperience or lack of knowledge, are not in a condition to operate the cabinet in a safe manner, must not use this cabinet without supervision or guidance from a responsible person.
4. The product is not a toy! Due to the risk of injury, you must not let children play with or in the vicinity of the product or play with the buttons. Have small children under supervision while you are using the product. Older children may only use the product if it has been explained to them how they can use it safely and are familiar with the dangers of erroneous use.
5. Check that the product does not have any visible damage. Do not install or use a damaged product. Contact the supplier immediately for further advice before you install/connect up the power cord.
6. The product contains the coolant Isobutane (R600a), a natural gas that is environmentally friendly. (R600a), that no parts of the cooling system have been damaged during transport or installation. Leaking coolant can injure the eyes. If the product has been damaged:

- a. Avoid open flames and everything that can create sparks.
- b. Disconnect the power cord.
- c. Air out the room where the product is located, for several minutes.
- d. Contact the supplier for further advice.



The more coolant a product contains, the larger the room it should be placed in. Leaking coolant can form a flammable gas-air mixture in a room that is too small. According to the EN378 standard, the room must have at least 1 m<sup>3</sup> for each 8 g of coolant. The quantity of coolant in the device is specified on the type plate on the inside of the product.

7. Before you connect up the power cord, you must check that the information on the type plate (voltage and connected load) accord with the power grid. This information must match up in order to avoid risks of damage to the product. Contact a qualified electrician if you have doubts.
8. Guarantees for the product's electrical safety may only be given when there is an uninterrupted connection between the product and an effective grounding system that complies with the applicable local and national regulations. It is extremely important that this fundamental safety requirement be fulfilled and checked regularly. In the event of any doubts, the wiring network in the house must be checked by a qualified electrician. The manufacturer cannot be held responsible for product damage or personal injuries that are due to a deficient or insufficient grounding system, such as electrical shocks for example.
9. If the wiring is damaged or other repairs are necessary, then the work may only be performed by an approved service technical such that the user is not exposed to any dangers.
10. A guarantee is made only for the product being safe to use if it has been installed and connected in accordance with these use and installation instructions.
11. Installation, maintenance and repairs must only be performed by an authorised repairman in accordance with national and local safety regulations. Repairs and other work by unqualified personnel may be dangerous and the manufacturer will not be held responsible. The power cord must not be connected to the power grid before maintenance or repairs have been performed.

- 12.** The product is only completely disconnected from the power supply when:
  - a.** the mains plug. has been pulled out
  - b.** The fuse in the house installation is completely disconnected
  - c.** The screw fuse has been removed (in countries where this is relevant)
- 13.** Do not connect the product to the power grid with an extension cord. Extension cords do not provide satisfactory safety for the product (involve for example a danger of overheating).
- 14.** Do not store explosive substances or products that contain propellants (for example aerosols) in the product. Thermostats that are activated can emit sparks and pose a fire hazard. Flammable substances may explode.
- 15.** Do not use electrical equipment in this product. Danger of sparks and explosion.
- 16.** Do not use oil or grease on the door seal, because oil and grease can damage the seal and gradually make it porous.
- 17.** Do not block the valve openings, because it will make the product less effective, increase its power consumption and the product may be damaged.
- 18.** The product is intended for use within definite climate classes (ambient temperature) and ought not to be used outside such limits. The climate class is specified on the type plate on the inside of the product and in chapter 6.
- 19.** Do not use a steam cleaner to clean the product. Steam can penetrate between the electronic components and cause short-circuits.



**CAUTION: RISK OF FIRE/FLAMMABLE MATERIALS**

This appliance is intended to be used in household and similar applications such as:

- Staff kitchen areas in shops, offices and other working environments.
- Farm houses and by clients in hotels, motels and other residential type environments.
- Bed and breakfast type environments.
- Catering and similar non-retail applications.
- If the supply cord is damaged, it must be replaced by the manufacturer, its service agent, or similarly qualified persons in order to avoid a hazard.

This appliance can be used by children aged from 8 years and above and people with reduced physical, sensory or mental capabilities or lack of experience and knowledge if they have been given supervision or instruction concerning use of the appliance in a safe way and understand the hazards involved.

Children shall not play with the appliance.

Cleaning and user maintenance shall not be made by children without supervision.

### 3. Product information

The Drawer Freezer is designed for maximum functionality and flexibility, whilst being a modern and exciting alternative to the traditional freezer. The Drawer Freezer module has a net volume of 104 litres with two external and one internal drawers. These can be fully extracted and are fitted with dividers and shock absorption.

The inside drawer is designed for relatively small food items, and its fittings can be moved/changed if required. The upper drawer can be used for almost all types of foods and has a flexible layout. The bottom drawer has been designed for storing heavier products. In the left back corner of the drawer there is a removable storage box. This box is perfect for storing bagged meat and the like.

**NOTE:** Do not wash the box in the dishwasher to avoid it becoming deformed!

The Drawer Freezer is available with stainless steel front and handle, or can be integrated with kitchen fronts (comes without handles).

This product is not designed for commercial use.

**NOTE:** The Drawer Freezer should be cleaned for ice removal twice a year. When cleaning, you must disconnect all power supplies.

## 4. Measures for energy conservation

### Measures for energy conservation

The most important energy conservation measure is that the Drawer Freezer doors must not be left open, this will cause increased running time and increased energy consumption. Having good order and organization in your Drawer Freezer will save you much searching and time, and you will reduce the running time and energy consumption.

- Install the product in a well-ventilated room. Make sure it is installed so that it is not in direct sunlight or near a heat source.
- Hot foods should always be cooled before it is inserted as this increases the frost formation and increases the running time.
- The food will thaw more gently and frozen food will emit refrigerant to the product and this will save travel time and energy.
- Do not fill the drawers with too much merchandise, it is important to have good air circulation to cool the food in the best possible way.
- Avoid that the drawers are open over time, place the goods so you can easily reach what you need.
- Clean the magnetic strip around the drawer regularly to prevent them from getting dirty and make sure they are not broken so that cold air is released.

## 5. Important information

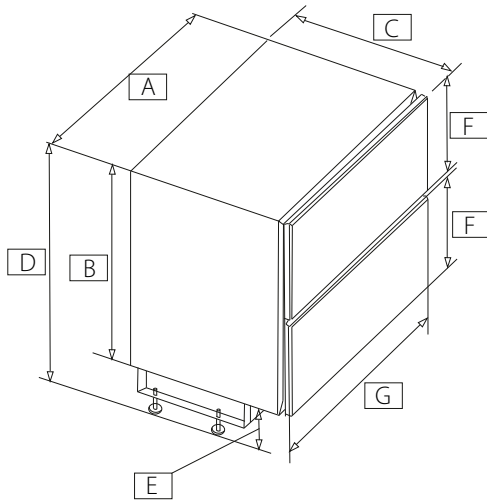
To ensure proper installation and use and thereby prolong the lifetime of the product, you must study this installation and user manual carefully prior to installation. Repairs must only be made by qualified personnel. The manufacturer will not assume liability for any damage resulting from non-compliance with the following instructions. Keep these instructions in a safe place as they contain many tips on use and regular maintenance. The product will require maintenance even in normal use and replacement of parts which are worn out can be necessary. These are not covered during the warranty period, but are covered by the guarantee in accordance with the Sale of Goods Act.

Overvoltage protection is recommended to protect the Drawer Freezer's electronics. Electrical safety for the appliance is only guaranteed if the earthing system in the house has been mounted in a manner in accordance with the regulations.

A data label with serial number is located on the inside bottom right corner. Serial number must always be stated when contacting service contractor or manufacturer.

Scandinavian Appliances AS disclaims all liability for typographical errors in this user manual and reserves the right to alter the product specifications.

## 6. Dimensions and technical specifications



- A** 795 mm
- B** 700 mm
- C** 565 mm
- D** Min. 820 – Max. 870 mm
- E** Min. 120 mm – Max. 170 mm
- F** 340 mm
- G** 788 mm

<b>Exterior dimensions</b>	W795 x H820 - 870 x D565 mm
<b>Niche dimensions</b>	W800 x H825 (min.) x D570 mm
<b>Usable volume</b>	104 liters
<b>Temperature range</b>	Approx. -18 °C ~ -24 °C
<b>Volt/Hz</b>	220 - 240V AC 50Hz
<b>Climate class</b>	N
<b>Energy class</b>	D
<b>Energy consumption</b>	328,865 kWh/year
<b>Noise level</b>	37 dB
<b>Defrosting</b>	Automatic
<b>Insulation</b>	Polyurethane foam, non-CFC
<b>Coolant</b>	R600A
<b>Weight</b>	Net 70 kg
<b>Weight pr. drawer</b>	20 kg (without steel/furniture panel)
<b>Drawers</b>	2 external
<b>Cable length</b>	2,4 m
<b>Ventilation requirement</b>	121 cm <sup>2</sup> x 2 (grids enclosed)
<b>Compressor</b>	Compressor cooling
<b>Kitchen front dimensions</b>	341-348 mm

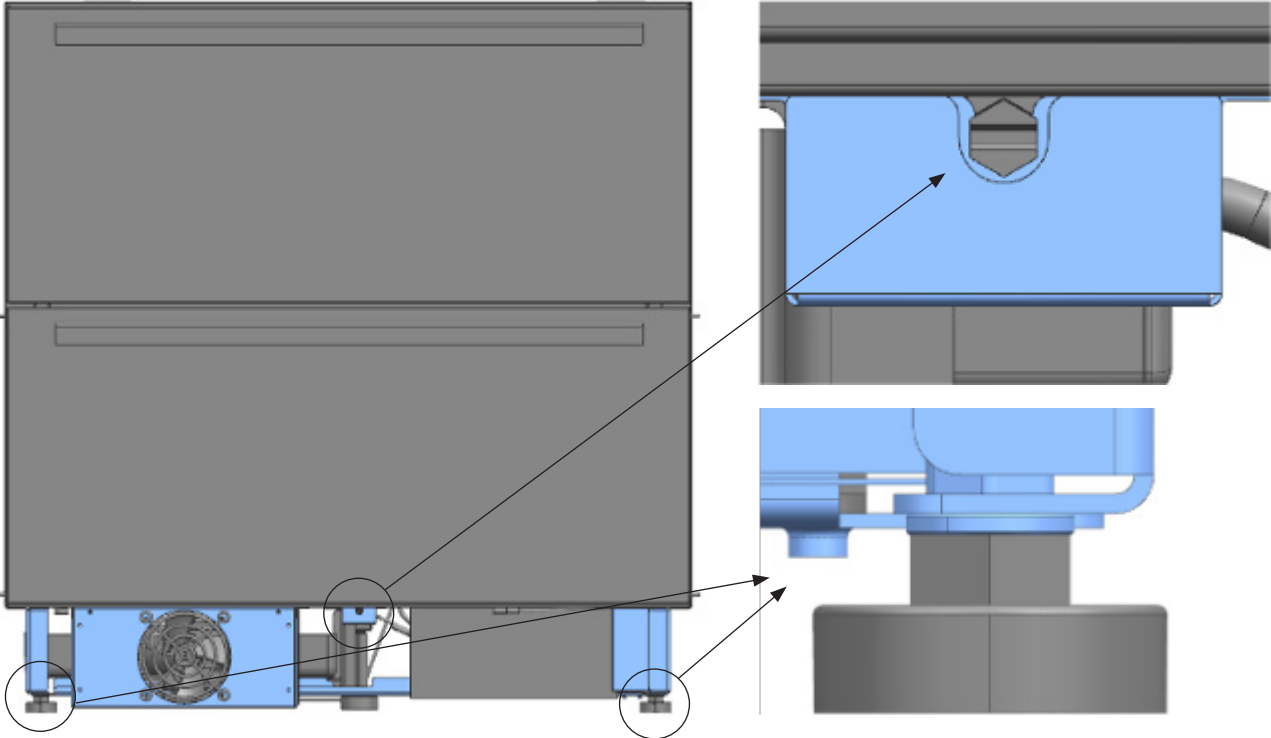
<b>Climate class</b>	<b>Ambient/ room temperature</b>
SN	+10 °C to + 32 °C
N	+16 °C to + 32 °C
ST	+16 °C to + 38 °C
T	+16 °C to + 43 °C
SN-ST	+10 °C to + 38 °C
SN-T	+10 °C to + 43 °C

### Climate range

According to climate specifications, this product should be operated at TEMPERATE (N) climate class, meaning between +16 to 32 °C ambient temperature range.

# 7. Back legs adjustment

Insert the slot type screwdriver into the hinge (red arrow indicated), rotate the screwdriver to adjust the height of the Drawer Freezer, after adjust the height of back leg, raise up the Drawer Freezer and adjust the height of front leg.



## 8. Pre-installation

Check for transport damage after unpacking. Do not use a damaged product. In the event of damage, please contact the shipping company and make sure that the damage is noted on the consignment note. Check that you have all the parts on the parts list at the back of this guide. Contact your vendor in the event of damage or missing parts.

The product must be connected to a 220V-240V 50 Hz earthed electrical power supply with at least a 10A fuse. We recommend placing the socket next to the product, for example in an adjoining unit.

This appliance will provide optimum performance at an ambient temperature of 16-32 °C.

This product is designed to be installed under a worktop, which must be fastened to the kitchen fittings and/or wall to ensure that it does not tip forward when drawers are pulled out.

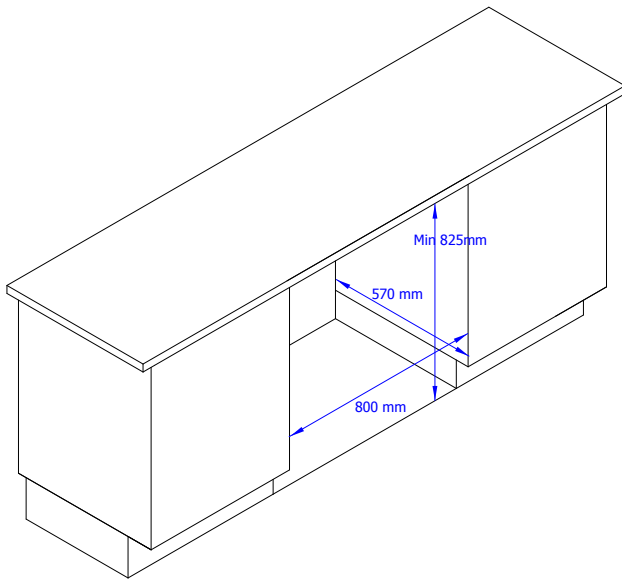
**This product cannot be used as a free-standing unit.**

# 9. Installation

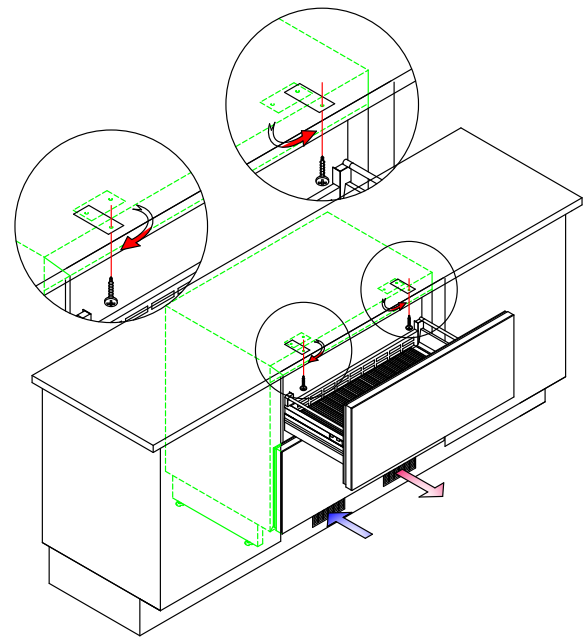
Requires a space of W 800 x H 825 (min.) – 870 (max.) x D 570 mm

Adjust the back levelling legs so that the back edge of the Drawer Freezer just clears the underside of the worktop. Fig 1. Extract retaining brackets Fig. 2.

Carefully slide the product into position and adjust the front legs so that the front edge squeezes firmly against the underside of the worktop. Fig 1.

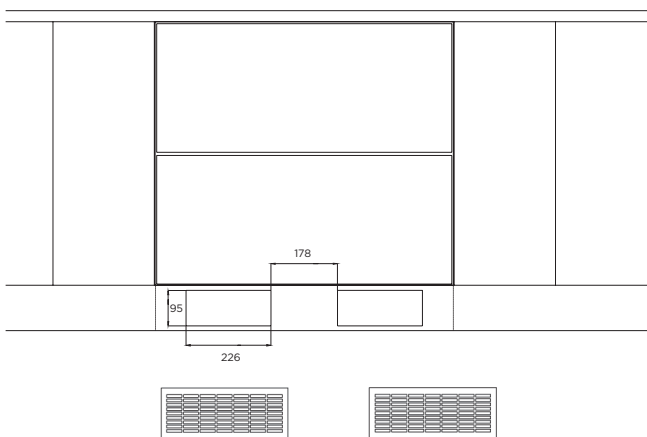


**Fig. 1**



**Fig. 2**

Pull out the upper drawer so that you get to the mounting bracket. Fasten the bracket beneath the worktop with the two supplied screws. This is to ensure that the product can't tip forward when the drawers are pulled out.

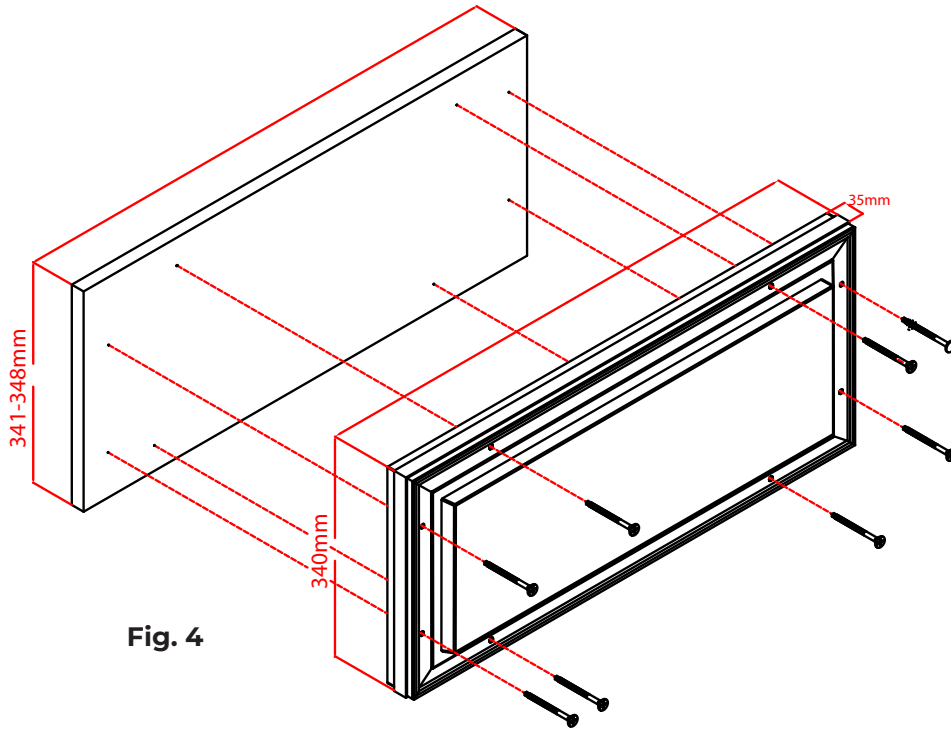


**Fig. 3**

The two enclosed ventilation grids are to be installed in the base in accordance with Fig. 3. To ensure the correct functioning of the appliance, these grilles must not be covered.

**Fitting furniture front.** Inside the drawer fronts there are 8 pre-marked holes in both upper and lower front doors. Drill holes by using  $\text{Ø}4,5\text{mm}$ . Attach the furniture front by using the included screws (4,2 x 45mm)

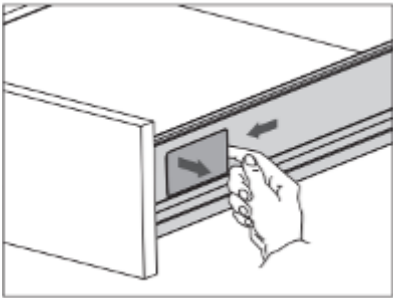
If mounting a black steel front or a stainless steel front, drill a 4,5 mm hole to secure the front/handle and use the panel as a template for drilling. Secure handle once panel has been fitted with expansion plugs.



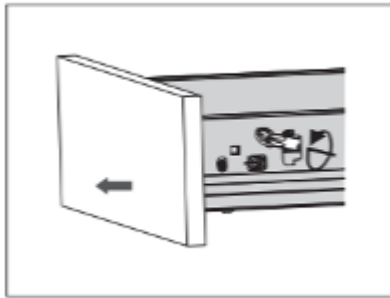
**Fig. 4**

## 10. Fitting/removing drawers

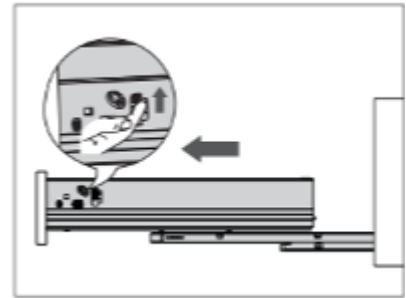
### 10.1 Removing front/drawer



Tip up the cover and pull out.

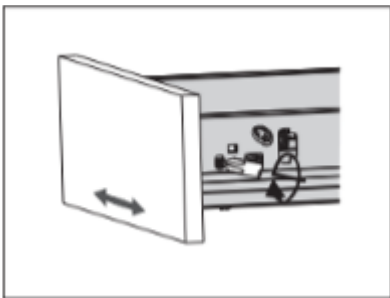


Turn screw driver to release the drawer front.

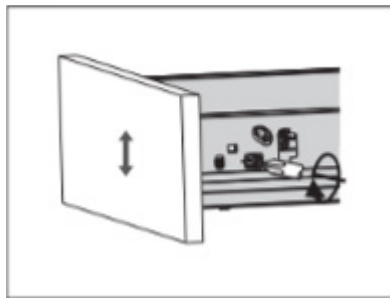


Lift the release handle and pull out the drawer.

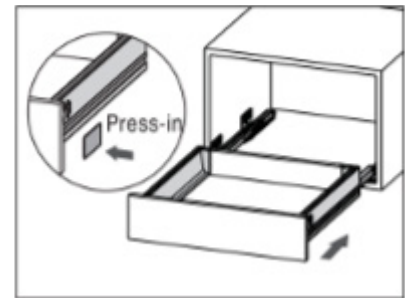
### 10.2 Side adjustment



Left & right adjustment.



Up & down adjustment.

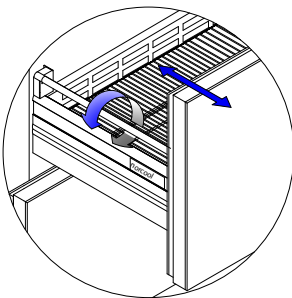


Slide into the cabinet.

### Inserting the drawers

Place the back edge of the drawer on the runners inside the cabinet, hold the drawer in a horizontal position and push it in until you hear the drawer locking into position. Carefully pull the drawer out to check that it is locked. Repeat if necessary.

### 10.3 Tilt adjustment



Vertical adjustment of the front. Make sure that the magnetic gasket seals adequately.

# 11. Use and maintenance

## 11.1 Prior to start

Allow the product to stand for about 2 hours before connecting power/start. This will allow the oil in the cooling system to collect in the compressor after transport/ installation. The product starts approx. 1 min after the power is connected.

If necessary, the thermostat located on the lower right side of the outside of the machine can be used to adjust the temperature.

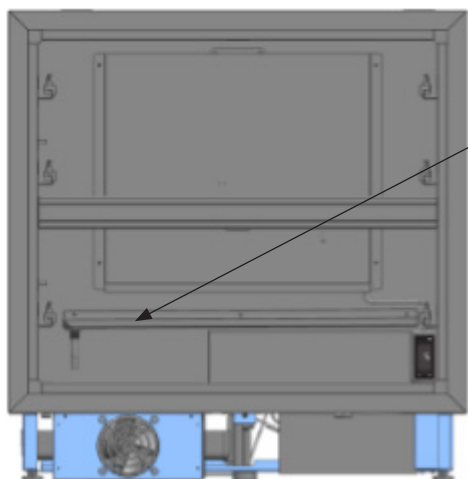
## 11.2 Maintenance

- To avoid mold, odors, etc., it is important to clean the product regularly. We recommend that you use mild, hot, soapy water.
- Collection gutter and drain hose inside should be cleaned at least two times per year and otherwise as required so that thawing water can flow freely out to evaporation bowl. Make sure the cleaning water does not leak into the evaporation bowl.
- Do not use harsh/caustic soap funds.
- Do not use a steam cleaner to clean the product. The steam can penetrate the electrical components and cause short circuit.

**NOTE:** The drawer runners must not be cleaned/lubricated/oiled. Wipe with a damp cloth in case of spills.

## 11.3 Manual defrosting

For manual defrosting, the bottom drawer must be removed, see chapter 10. Then place a towel over the drain on the left side in the cold drip tray, (this is done to reduce the chance of the drip tray on the warm side becoming full and overflowing (see below picture). Make sure to take care of the defrost water so that no consequential damage occurs.



Place the towel in water tray when defrosting to avoid water overflow.

## 11.4 Noises

Norcool Drawer Freezer is quiet, but some noise can be expected.

- Humming from the compressor. Can increase when the motor starts up.
- Gurgling can occur from coolant in the pipes
- Humming from the circulation fans

## 11.5 Display panel



### 1. Temperature Setting

- Setting temperature range:  $-18^{\circ}\text{C} \sim -24^{\circ}\text{C}$ . Default is  $-18^{\circ}\text{C}$ .
- Short press “up” and “down” to set. Support long press to continuous adjustment.

### 2. Light/Mute

- Long press “Light/Mute” for 6s to keep the LED lamps on, and long press again to return to the normal mode.
- If any door is opened over 60s, buzzer will alarm.  
Press “Light/Mute” to stop alarm.

### 3. Temperature display

The display panel shows setting temperature in normal. If there is no button operation for a long time, the display panel will automatically turn off. Pressing any key will relight the display panel. Other messages:

- E0: Open or short-circuited probe 1. (Air probe)
- E1: Open or short-circuited probe 2. (Defrost probe)
- E2: Open or short-circuited probe 3. (Water box probe)
- OF: Off Mode

Cold flag: If the compressor is on, the flag is lit.

Display flag: This flag is lit in display mode, and off in normal mode.

### 4. Defrost

Defrost period:

- Run time  $\geq 6\text{h}$
- Defrost stops when: defrost sensor  $\geq 6^{\circ}\text{C}$  or defrost time  $\geq 45\text{min}$
- If the defrost probe failed, defrost stops when: defrost time  $\geq 45\text{min}$

## 11.6 Troubleshooting and service

Make sure the ventilation grids are mounted in the base according to installation instructions. See Figure 3.

<b>Fault</b>	<b>Cause</b>	<b>Remedy</b>
<b>Not cooling</b>	Ambient temperature is too high	Lower the temperature in the room and check that the air grids are not blocked
	The cooler is not running	Check the mains plug and the fuses in the house
	The thermostat controller is set to warm	Increase the temperature
	Drawer is not closed	Check that the drawer has full movement without obstructions
	Evaporator iced up	Manual defrost. See page 16
<b>The temperature is too cold</b>	The thermostat controller is set too cold	Lower the temperature
<b>Compressor does not run</b>		Order service on our website
<b>Fan not working</b>		Order service on our website
<b>Display E0</b>	Air probe error	Order service on our website
<b>Display E1</b>	Defrost probe error	Order service on our website
<b>Display E2</b>	Water box probe error	Order service on our website
<b>Display Ht</b>	Not cooling	Power off and order service on our website

For service, visit our web site at [en.norcool.com](http://en.norcool.com). By having checked these points before summoning help, you will help the service technician with the parts that might need to be brought along and the specific measures that may need to be taken.

## 12. Delivery terms and conditions

Delivery terms and conditions for Norway. For other countries, contact your dealer.

### 12.1 Consumer purchases

These terms and conditions govern customer rights with respect to the supplier (Norcool) when purchasing new Norcool products that will be used in a normal manner in private housekeeping. Such as is determined in the following points, the supplier is obligated to remedy defects/omissions that arise.

#### 1. Supplier's warranty

The supplier warrants that the product as it is delivered has the characteristics and the quality that has been prescribed in the supplier's brochures or other written sales material. Minor deviations may occur in consequence of product changes. The warranty period runs for 2 years commencing on the day the product was delivered to the customer. Due to these devices having a complicated technical design, it is important that the customers follow the instructions for use carefully. The products will even with normal use be subjected to wear that may necessitate preventive maintenance, and thereby also replacement of wearing components (fans, starting equipment, compressor component with a variable lifespan depending upon their use and maintenance).

#### 2. Purchaser's rights

The deadline for making claims with consumer purchases is 2 years. When the equipment or parts of it is intended to last significantly longer in normal use, the deadline for claims is 5 years. For such claims, it is a precondition for the liability for the deficiency to be valid that the deficiency was present at the point in time of delivery. Customers will in all instances lose their right to pursue claims if they do not make a claim within a reasonable period of time after they have detected, or ought to have detected, the deficiency. In the event of deficiencies related to purchasing law, the supplier has the right to repair the product with the deadlines that follow from the Sale of Goods Act. After the warranty period has expired, the terms and conditions for the scope of the supplier's liability for deficiencies in the equipment will be governed by the Sale of Goods Act.

#### 3. Supplier's remediation (transport of products)

The supplier and/or dealer in the supplier's products may decide whether defects/ omissions may be repaired at the customer site, at its own site, or at a designated workshop in accordance with the following guidelines.

a) The customer is obligated to place the product at the disposition of the repair technician. The supplier will defray the expenses of the repairs. This applies for products that are located within the natural sales territory of the supplier or distributor! What is meant by natural sales territory is a distance between the supplier/ dealer and customer by road of max. 20 km. If the distance is more than 20 km, and the dealer is the entity located closest to the customer, then the supplier will pay the travel costs regardless. If this would bring about unreasonable costs or drawbacks, then the obligation to undertake the remediation as mentioned above at no cost to the customer does not apply! Normally, this instance would be if the customer is unable to be reached by normal means of communication, and/or if the customer does not live where there is a connection to the mainland.

b) Repairs/Remediation at the workshop. If customers can bring in and fetch the product without significant drawbacks, then they must bring it in to the designated workshop for repairs, or ship the product, in such case at their own expense and risk. If customers are unable to bring the product in to a specified workshop without unreasonable drawbacks and/or costs, then such in the lack of any other agreement occur in the most reasonable manner, and be sent at the supplier's expense and risk to the specified workshop.

**NOTE: THE PRODUCT MUST BE PROPERLY PACKAGED!**

#### **4. Supplier's liability to pay compensation**

Customers may under more detailed terms and conditions demand compensation for financial losses pursuant to the rules of the Sale of Goods Act. The Supplier is however in no instance liable for indirect losses (as mentioned in the Sale of Goods Act, section 67(2)). If damage is inflicted on objects that have a direct or close interrelationship with the product's stipulated function or use, then the supplier is only liable to the extent such are consequences of rules of law that cannot be deviated from. The same applies for liability for personal injuries. Damages and injuries of this nature shall in every instance be handled between the supplier and customer.

#### **5. What the supplier's liability does not encompass**

Customers have no ability to pursue claims against the supplier or dealer if defects/ omissions, or any possible damages/injuries, are a consequence of:

- a) Installation that has not been performed in accordance with the electric utility's provisions or is in violation of our installation instructions that are to be deemed to be requirements. The cold room must in terms of its technical construction satisfy the applicable requirements, including requirements for insulation, choice of materials and ventilation.
- b) Actions in violation of the instructions for use, or other indefensible actions. (Lack of maintenance!)
- c) Repairs or interventions performed by unauthorised persons, or use of nonoriginal parts.
- d) Accidents or other circumstances after delivery to the customer that lie outside the control of the supplier/dealer, including voltage fluctuations beyond +/- 10 % of the rated voltage, lightning strikes, and electrical power outages.
- e) Corrosion/deposits due to the surroundings.
- f) Normal wear. (See point 1)

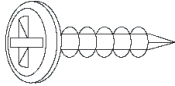
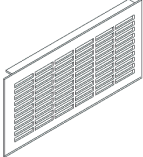
#### **6. Disputes**

Disputes that concern the application of these terms and conditions may, via the consumer council's complaints mechanism, be brought in for resolution by the industry's complaints tribunal.

#### **12.2 Business purchase**

What is to be understood by business purchase is everything that is not a consumer purchase and which is used for example in cafes, restaurants, snack bars, hotels, motels, companies, or other business-related activity. As well as use in schools, institutions, rented rooms, preschools, athletics facilities, shared households, and housing cooperatives, plus instances where the customer in full or in part receives payment for use of the device, or where it is included in a shared house, possibly a leasing relationship. Or where the device is used to maintain a good that the customer sells. All these things are business purchases. The period for filing claims and the warranty period is then 6 months. This applies for any losses that the deficiency might cause, for example such as operating losses, lost earnings and other consequential financial losses. This limitation to the supplier's liability does not apply if it is guilty of acting with gross negligence.

## 13. Package list

Figure	Description	Ref. no	Qty.
Drawer Freezer for integration			
	Plate screw 4.2 x 16	8900013865	2
	Air grid black	8900013866	2







Scandinavian Appliances AS  
Postboks 61  
1740 Borgenhaugen  
Norway  
T: +47 815 69 117  
post@norcool.no

[en.norcool.com](https://en.norcool.com)

Please visit our website for operating &  
installation instructions in other languages.



Version 1.0 - October 2025